



**Joist**

# **Reinforcement**

Draft 12/7/02

## **JOIST REINFORCING**

The purpose of this CSD Design Aid is to provide procedures and suggested details for the reinforcement of open web steel joists. There are three basic methods of reinforcing a joist system for additional loading:

1. Load Distribution.
2. Adding new joists or beams.
3. Reinforcing the existing joists.

Before deciding which method of reinforcing is appropriate obtain as much information about the joist system to be reinforced as possible. This normally requires a trip to the site, or obtaining detailed information from the client. Required information includes:

1. Type of web members (including end diagonal):
  - a. Rod webs (usually K and H-series < 24" in depth)
  - b. Crimped webs (usually K and H-series > 24" in depth)
  - c. Angles welded to the outside of the chords (some LH and JG)
2. Type of chords (obtain sizes, thicknesses, separation distance):
  - a. Double angles
  - b. Cold formed sections
  - c. Rods
3. Bridging Locations.
4. Interferences.
5. Condition of joists.

Also, obtain the joist tag(s) that are wired to the joists. The joist tag will give information regarding the manufacturer and the size of the joist.

### **Existing Joist Capacity:**

The next step is to determine the existing joist capacity. This can be done from the SJI Load Tables. The SJI Seventy Five Year Digest (1928-2003) can be helpful. Also, make use of the SJI Specification for the joist in question to determine capacities. The specification requirements for web member capacity are especially useful (LH joists web members were to be designed for 50% of the end reaction; whereas, K series joists only 25%). If historical data regarding the joist system is unavailable then more detailed measurements will be required to calculate the joist capacity. Remember the joist manufacturer only welds the diagonals with enough weld to carry the design loads, not the member size.

## **Load Redistribution:**

Before investigating if individual joists require reinforcing determine if the new loads can be distributed throughout the system so that the loads are reduced on individual joists to the point that they may not require reinforcement, or only minimal reinforcement. The basic concept is that if a member can be placed under or through the joist as shown in Fig. 1, and if the member has suitable stiffness, then concentrated load can be distributed to several joists rather than one or two joists. Equations are presented in the Vulcraft Joist Book, “Designing with Steel Joists, Joist Girders, and Steel Deck” for the stiffness determination. You can also model the joists to get their stiffness, or get the stiffness from the SJI load tables (method is shown in the load tables). Then model the joists as springs to determine the load distribution. In lieu of a beam, it is also possible to add X-bridging between the joists to distribute load.

## **Adding new joists or beams**

Also you should consider adding new joists or wide flange beams before using expensive reinforcement solutions. Of major concern in adding joists or beams are existing interferences. It may not be practical to add members because piping, electrical conduits, or other interference may have to be removed or relocated at a greater expense than reinforcing. If joists are to be added, consideration must be given to camber, the ability to insert the joists or beam in place, and seat depths. Seat depths should be ordered to a 2 in. height and then shimmed to facilitate erection. The best method is to have the joist manufacturer provide a center splice so that two individual pieces can be installed and then bolted at the center.

## **Reinforcing Joists**

The type of reinforcement, and details to be used, are dependent on the geometry of the joist or joist girder to be strengthened. The following items have an impact on the solution for both chord and web reinforcement:

1. Rod web members.
2. Crimped angle web members (many crimped web joists have rod end diagonals)
3. Web angles welded to the sides of the chords.

## **Design Approaches:**

There are two design approaches with respect to reinforcing joists. *Approach I*, is to ignore the existing strength of the members. Although this is conservative, it avoids load distribution concerns between the reinforcing member and the existing member. This approach is not generally used for chord reinforcement, but can be used.

**Approach II**, is to make use of the strength of the existing member.

When using either approach, remember that the cost of materials for reinforcing joists is almost insignificant to the cost of the field labor.

**Shoring:**

With either design approach it is best to reinforce the joist or joist girders in the shored position. This is a safety issue. Welding can generate enough heat to cause a temporary loss of yield strength in the steel. This is particularly true if welds are made transverse to the axis of the member. With the loss of yield strength the member can sag excessively or even collapse, thus shoring should be placed tight against the joist being reinforced. It is also best to reinforce members with the dead, live and collateral loads removed. This can be done by calculating the amount of load present on the joist and then jacking the joist up to a calculated deflection that corresponds to the load on the joist. In most cases a minimum of two jack locations should be used.

**Approach I:**

If Approach I, is used there are no special considerations that need to be addressed. Simply design the reinforcing members to carry the total load.

**Approach II:**

For Approach II, it is assumed that applied forces are distributed between the existing member and the reinforcing member in direct proportion to their areas. Any pre-load is assumed to exist only in the existing member. It is suggested that LRFD procedures be used to determine reinforcing requirements.

**Terminology and terms used:**

*Composite section* - Combined existing member and reinforcing member.

*Initial force* – Force in the existing member not removed by shoring.

*End welds* – Welds at the ends of the existing member or the reinforcing member.

*Existing member* – The member originally supplied on the joist or joist girder

*Reinforcing member* – The added member(s).

*Required force* – The total force to be carried by the chord or web member.

$\Phi R_{ew}$  = design end weld strength.

$\Phi R_{ea}$  = existing member design strength.

$\Phi_{RL}$  = lower bound of  $\Phi R_{ew}$  and  $\Phi R_{ea}$

$A_T$  = area of existing member and reinforcing.

$A_e$  = area of existing member.

$A_r$  = area of reinforcing.

$P_P$  = preload in the existing member

- $P_r$  = force in the reinforcing.  
 $P_{rw}$  = required force in the reinforcing end weld.

***Design of reinforcing for tension members:***

1. Determine the weld design strength for the existing member,  $\Phi R_{ew}$ . Note: SJI requires that weld strength be a minimum of 2.0 times the design force, thus, if the original force in the member is known, the weld strength is 2.0 times the original design force.
2. Determine the existing member design strength,  $\Phi R_{ea}$ .
3. Obtain the lower bound from 1.), and 2.),  $\Phi R_L$ .
4. Determine the total area required (existing area plus reinforcing area), and the area of the required reinforcing using the equations:

$$A_T = \frac{(P_T - P_p)}{P_L} (A_e)$$

$$A_r = A_T - A_i$$

5. Design the weld size and length for the reinforcing member. The force in the weld is:

$$P_{rw} = \left( \frac{A_r}{A_T} \right) (P_r - P_p).$$

***Design of reinforcing for compression members:***

1. Perform steps 1-4 from above to obtain a trial  $A_r$ .
2. Using the trial reinforcing determine the composite section properties of the reinforcing and the existing member to check buckling. If a pre-load exists first determine the magnitude of the compressive stress in the existing member due to the preload,  $f_p$ . For the buckling check, use  $F_y$  as the minimum of  $(F_{ye} - f_p)$ , and  $F_y$  of the reinforcing member. Where  $F_{ye}$  is the yield stress of the reinforcing material.
3. Design the weld size and length for the reinforcing member. The force in the weld is:

$$P_{rw} = \left( \frac{A_r}{A_T} \right) (P_r - P_p).$$

Alternately the weld on the existing member can be reinforced to take the entire axial load.

### **Chord Reinforcement:**

Shown in Fig. 2 are several details that have been used to reinforce the top or bottom chords of joists. Top chord reinforcement usually presents a bigger problem than the bottom chord, because roof or floor deck is usually in place and interferes with the placement of reinforcement and welding. For joists and joist girders where the web members are attached to the outside of the vertical legs of the chords (See Fig. 5), the web members are often tight against the outstanding chord legs. In this case the details shown in Figs. 2a thru 2d will probably not work. Details such as shown in Figs. 2e or 4 could be used. The detail shown in Fig. 2c will not generally work for joists but can work in some cases for joist girder reinforcement where down hand welds can be made. If splicing of the rounds is required consider the splice detail shown in Fig 2f. The splice will most likely be made in a shop or on the ground and then lifted into place.

The easiest type of bottom chord reinforcement is shown in Fig. 3. On occasion the detail shown in Fig. 4 may be required for either top or bottom chords.

### **Web Reinforcement:**

#### **Rod Web Members:**

Rod web joists are the easiest to reinforce since the webs do not interfere with chord reinforcement, and the reinforcing web diagonals can be welded to the chords directly. If the top chord requires reinforcement the reinforcing will reduce the available length of the end weld for web members. See Figure 6. If a plate can be used to reinforce the bottom chord then web end weld length is not reduced.

#### **Crimped Angle Web Members:**

Shown in Fig. 7 is a joist with crimped web members. Notice how the web member protrudes beyond the vertical leg of the top chord. This prevents placing a new web member along side and welding to the chord leg.

#### **Crimped Web Member Reinforcement:**

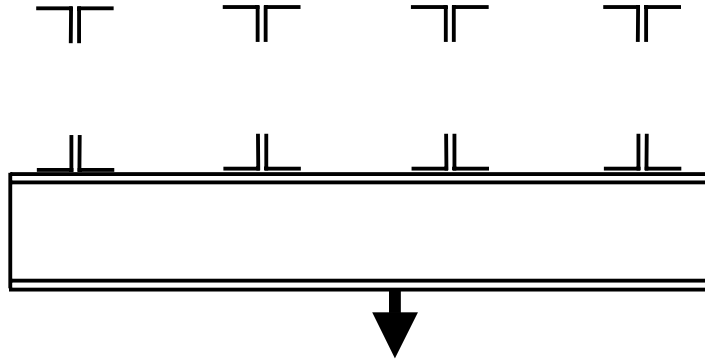
Shown in Fig. 8 is a method of reinforcing the joints of crimped web members. A round can be laid adjacent to the chords and the web, and flare bevel welds can be used to transfer the loads from the web member. Shown in Fig. 9 is the condition where the web member and the joint require additional reinforcement. The strength of the crimped web can be added to the plate strength provided the new joint design is capable of transferring the entire load to the chord. Shown in Figs. 10 – 13 are alternate details for reinforcing crimped web members.

## **Web Angles Welded to the Sides of the Chords**

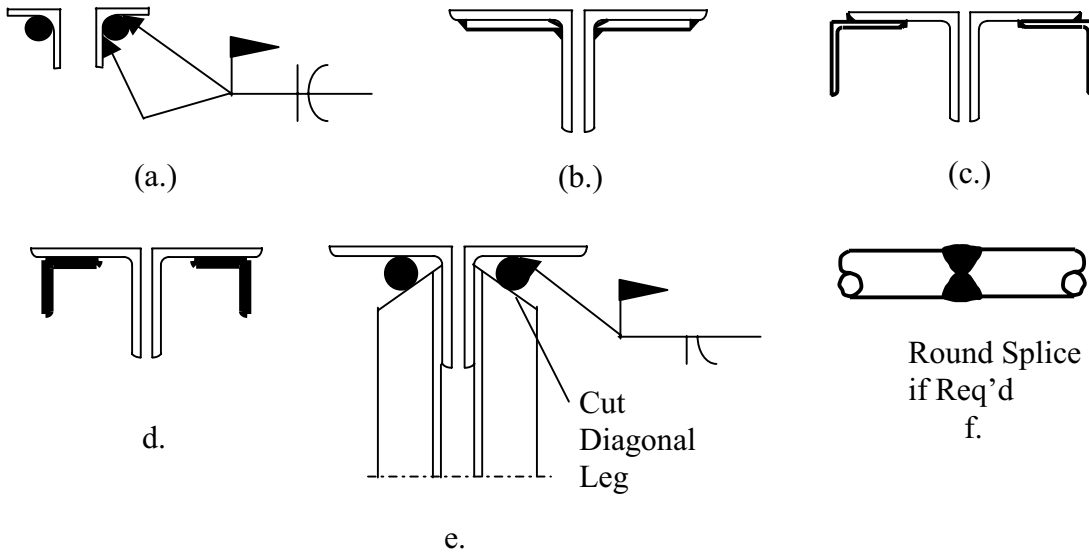
A photo illustrating web angles welded to the sides of a chord is shown in Fig. 14. Illustrated in Fig. 15 is reinforcement added to the web member. End weld may have to be added to the existing angles to transfer the load from the reinforcing into the chord. Usually this weld can be added to the heel of the existing angle. Gussets may also be added as shown in Fig. 16. Generally two gussets are used since a gap exists between the chord angles. Also shown in Fig. 16 is the web angle leg removed to facilitate chord reinforcing.

## **End Diagonals**

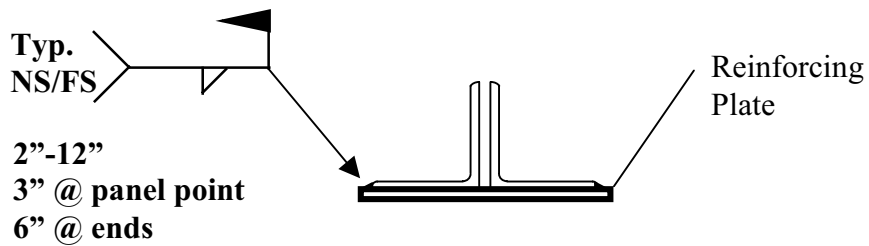
Examples of reinforcing on end diagonals is shown in Figs. 17 and 18.



**Fig. 1 Load Distribution**

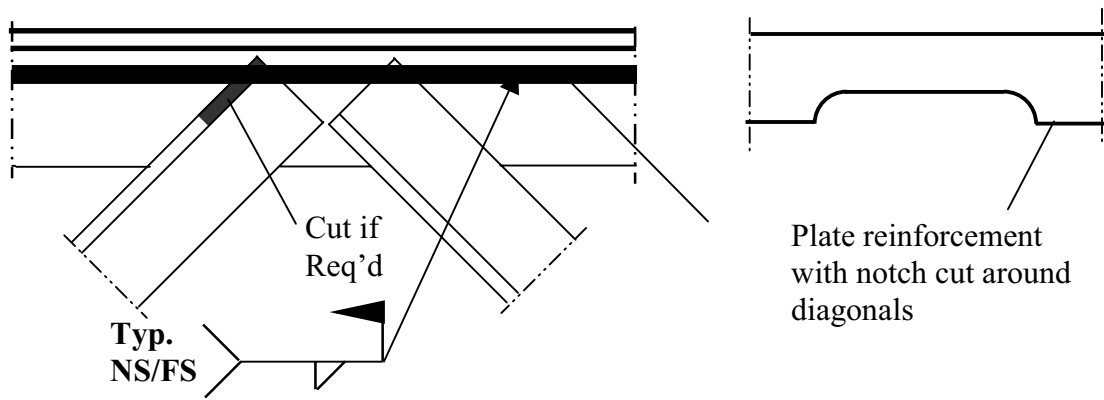


**Fig. 2 Top Chord Reinforcement**



**Fig. 3 Bottom Chord Reinforcement**

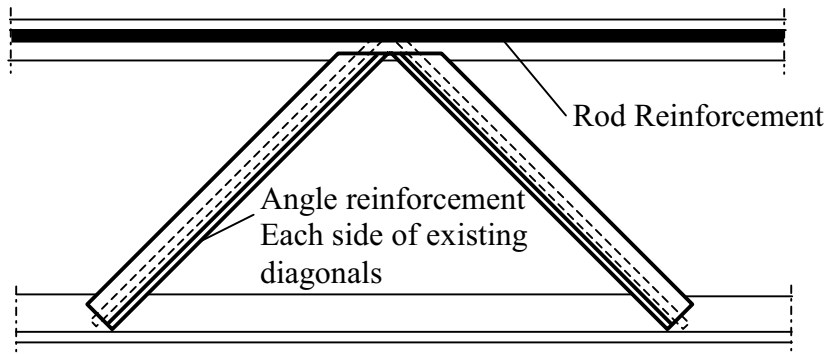




**Fig. 4 Chord Reinforcement Requiring Notch**



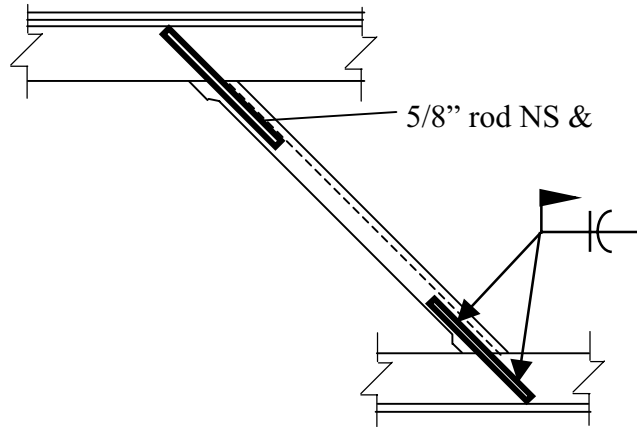
**Fig. 5 Angles interfering with Top Chord Reinforcement**



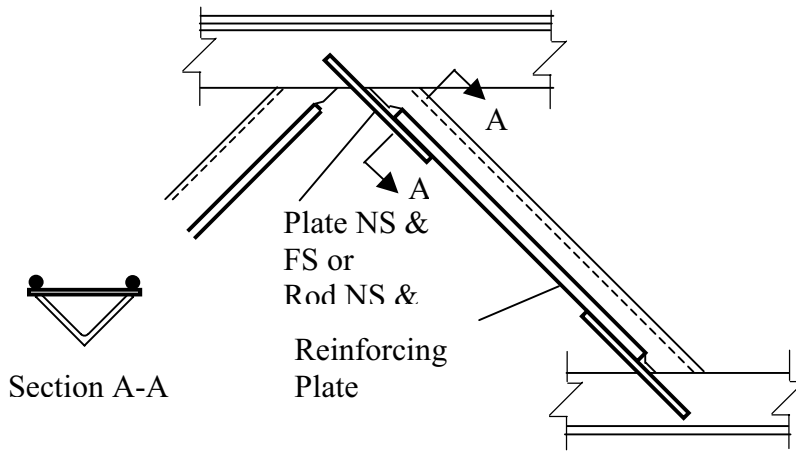
**Fig. 6 Angle Reinforcement on Rod Web Joist**



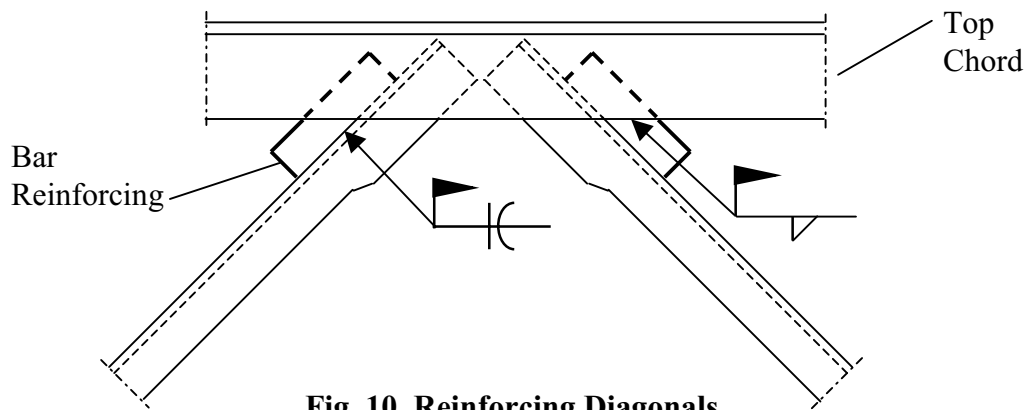
**Fig. 7 Joist with Crimped Web Members.**



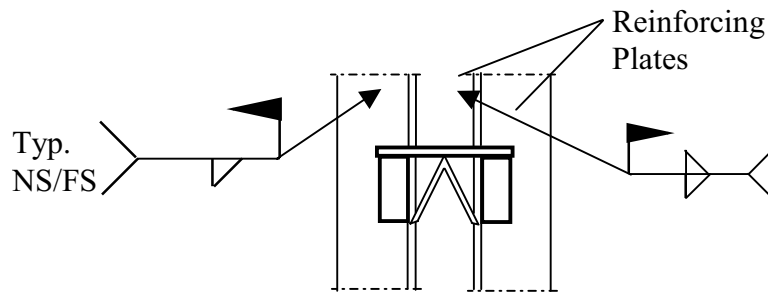
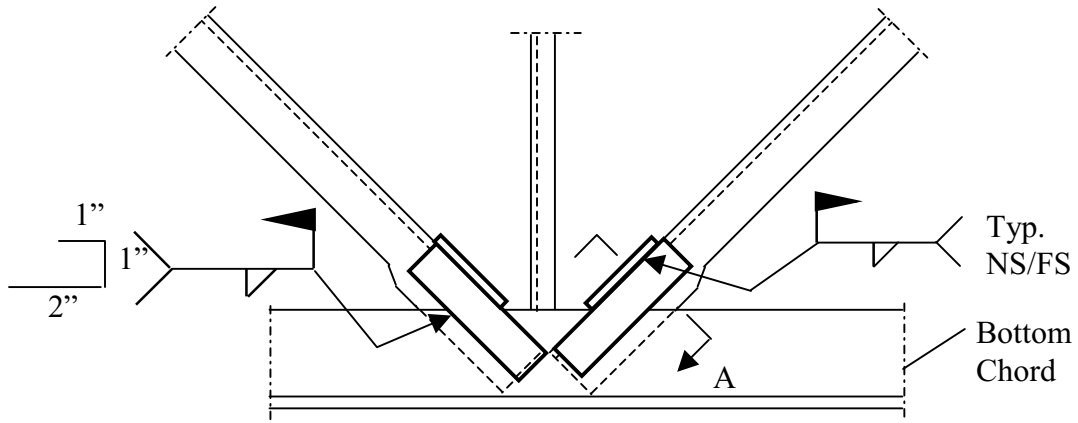
**Fig. 8 Weld only Reinforcement**



**Fig. 9 Crimped Web Reinforcement**

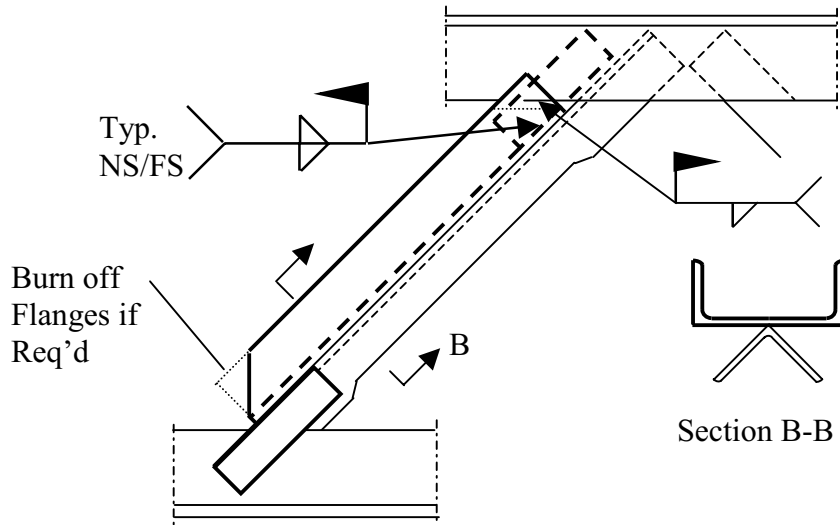


**Fig. 10 Reinforcing Diagonals**

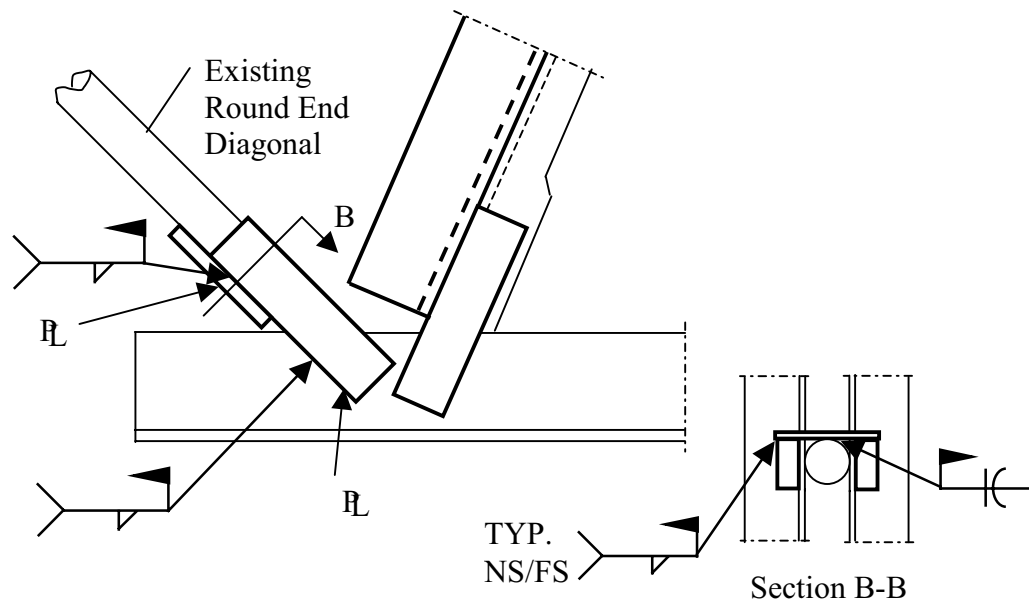


Section A-A

**Fig. 11 Reinforcing Diagonals**



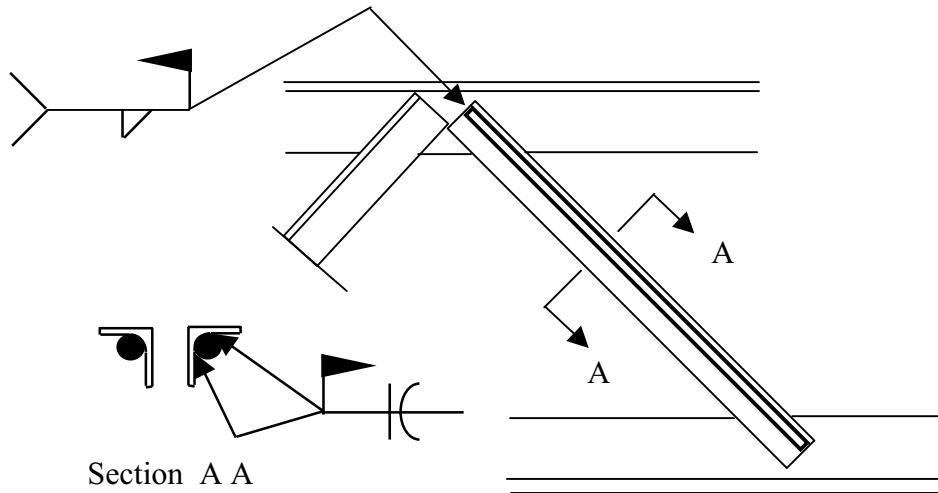
**Fig. 12 Channel Reinforcing**



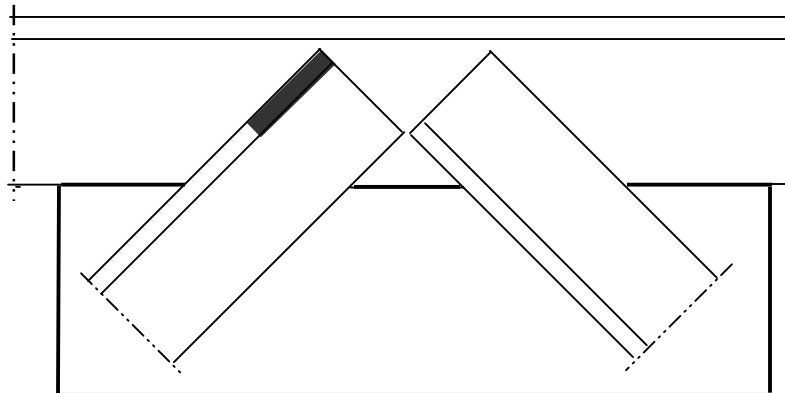
**Fig. 13 Channel Reinforcing at End Diagonal**



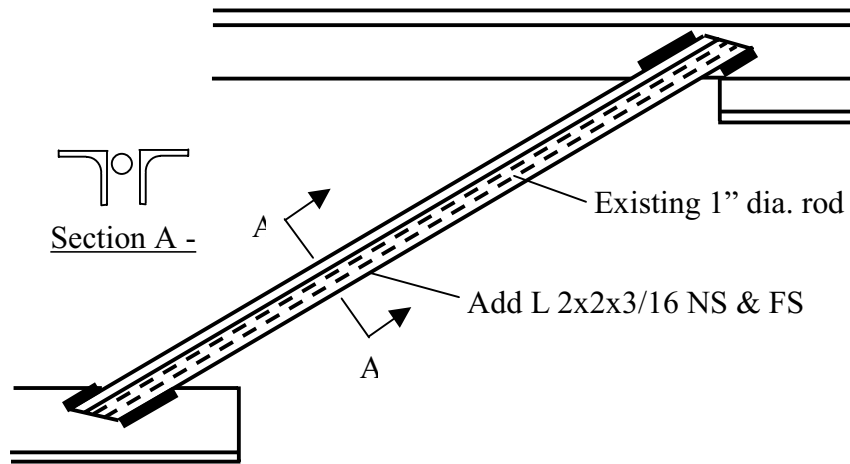
**Fig. 14 Web Angles on Side of Chords**



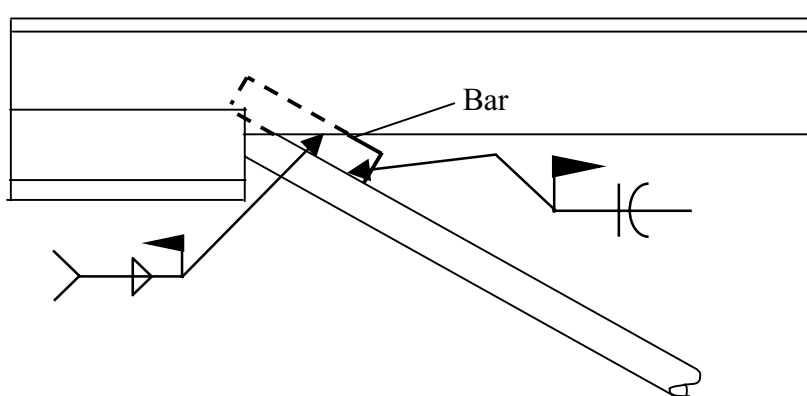
**Fig. 15 Rod Reinforcing**



**Fig. 16 Added Gusset Plate for Weld Requirements**



**Fig. 17 Angles and Welds Added**



**Fig. 18 Bar Added for Additional Weld**