

Joist the Facts

BY PERRY GREEN AND TODD ALWOOD

A successful and economical steel joist project relies on such factors as providing the right information to the joist manufacturer and using top chord extensions correctly.

WHETHER YOU'RE IN THE MIDDLE OF A STEEL JOIST PROJECT OR ARE CONSIDERING ONE, YOU PROBABLY ALREADY KNOW THAT JOISTS ARE A COST-EFFECTIVE FRAMING OPTION FOR MANY BUILDING TYPES AND CONFIGURATIONS. They are easy to use and provide a great deal of flexibility for loading conditions, span lengths and depths, member configurations, or other special considerations.

It is important that the design requirements established by the structural engineer are clearly conveyed to the joist manufacturer so that the joist design is both economical and meets code requirements.

The Right Stuff

When it comes to special joists, there are several items important to the joist manufacturer that should be included in construction documents, but are often overlooked. Perhaps the most important three are:

Identifying the correct load combination. The joist manufacturer will design the joists for the load combinations specified on the contract drawings. Specifying which section was used for the overall building structure will ensure that the joists are designed to the same load combinations. If a different set of load combinations is required, they should be specified on the contract drawings.

Noting the amount of net uplift. It is important for the structural engineer to provide net uplift values in areas where the joist manufacturer is considering uplift in the joist or joist girder design. If the uplift forces shown on the contract drawings are displayed as gross uplift, the joist manufacturer may conservatively design for the full force without deducting any dead load—not a cost-effective move—and

may need to have the net uplift value verified by the engineer. Many contract drawings do not show the dead loads used in design, and even if they are shown, it's up to the engineer to decide if some of the dead load could be considered collateral and therefore not be deducted from the gross uplift.

Defining E and E_m . For earthquake loads, the joist manufacturer will use different load combinations for E and E_m loads, so the contract drawings need to make a clear distinction between these two types of loads. Without this information, the project schedule could be delayed in order to procure this information. Another negative potential result is that the joist girders might be designed too conservatively.

Extend It!

Top chord extensions are a common but forgotten advantage of steel joists. They are used to create eaves or awnings and can support a wide variety of elements such as cantilevered walkways. In Figure 1, one can see the two different call outs: Simple (S-Type) or Reinforced (R-Type).

The Steel Joist Institute (SJI) standard specifications have tables for top chord extensions and extended ends that provide the load capacity for various lengths of types S1 through S12 and R1 through R12 extensions; these ranges refer to the different angle sizes being used. It is important to note that although an S-type can be as long as 4 ft, 6 in., the maximum load rating for this extension is only 113 plf.

The structural engineer should review the top chord extension load table and extended end load table to ensure that an extension can be manufactured for the length and loads required for the project (see Figure 2). If there are concentrated loads or snow drift loads on the extension,

they need to be resolved into an equivalent uniform load and added to the dead and live loads on the extension. This will allow the engineer to properly size and specify the extension needed. The top chord extensions given in the SJI Standard Specifications can be used for K-Series, LH-Series, or DLH-Series joists. The following are SJI's "standard" bearing seat depths:

- K-Series: 2½ in.
- LH-Series: 5 in.
- DLH-Series: 7½ in.

However, note that a 5-in.-deep seat can be used on a K-Series joist and a 4-in.-deep seat can be used on a LH-Series joist. When the joists are installed at a slope, the minimum required bearing seat depth may have to be increased. Most joist manufac-

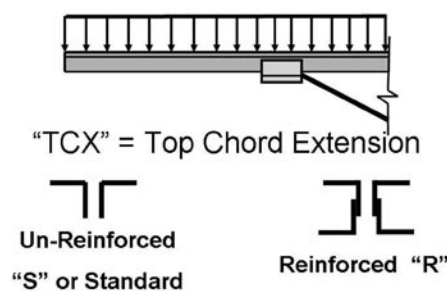

Figure 1.

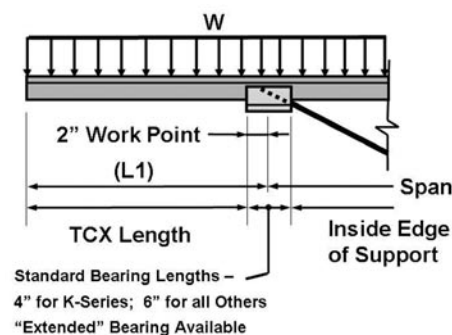

Figure 2.

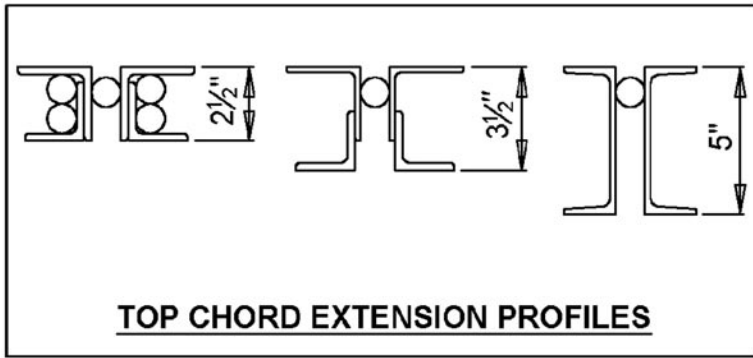

Figure 3.

turer catalogs provide a table that gives the minimum required bearing seat depths for a given slope. Stating these minimum bearing seat depths on the construction documents in accordance with these tables will not only reduce the number of RFIs on a project, but will also speed up the detailing and manufacturing schedule.

When the loads for a top chord extension of a given length are greater than the values given in one of the above-mentioned tables, it is an indication that the given seat dimension will not work. So what bearing seat depth should be specified? A good rule of thumb, in most cases, is that the depth of the bearing seat in inches should be equal to the length of the extension in feet.

As an example, consider an R-Type joist extension with a length of 5 ft, 6 in., a 280-plf load on the joist and extension, and a 1,000-lb concentrated load at the end of the extension. The equivalent uniform load on the extension is: $280 + (2 \times 1,000)/5.5 = 644$ plf. According to the extended end load table (R-Type) the maximum load on a 5-ft, 6-in. extension is 375 plf for a type R12 extended end. Therefore, a 2½-in.-deep bearing seat will not work for this joist. Based on the rule of thumb, the bearing seat depth should be increased to 5 in. Figure 3 illustrates the difference an appropriate top chord extension depth can make. For the example, the loads and span of the top chord extension were such that the maximum angle sizes available for use in the specified 2½-in.-deep extension were not structurally adequate, so the manufacturer added four round bars to strengthen this section. As illustrated in Figure 3, a depth of 3½ in. would have allowed the manufacturer to use a more conventional four angle top chord extension. If a depth of 5 in. had been allowed, the manufacturer would have had the option of using two C5 channels to form the top chord extension. From this, one can see that increasing the extension depth simplifies the construction

and therefore the overall cost. In addition, if the joist was also to be installed at a slope, the bearing seat depth may have had to be further increased to account for the slope.

Bridging the Gap

While many engineers envision the top and bottom chord bridging aligning in the same vertical plane, this configuration is not necessary or required. In fact, there's a potential cost savings if the spacing of the bridging rows is varied according to the structural needs. This is particularly true in regions with high uplift values. The engineer of record should avoid dimensioning specific bridging line locations on the contract drawings, since this will give the joist manufacturer the ability to optimize the bridging layout. In fact, it is sufficient, and sometimes cost-effective, to state on the contract drawings: "Bridging as required per SJI."

The structural engineer should also be aware that when selecting the joist, the lightest joist may not be the most economical. For example, if a lighter joist requires erection stability bridging (bolted diagonal bridging), or a slightly heavier joist only requires standard horizontal bridging, the amount of time and additional labor cost savings will far outweigh selecting the heavier section. The load tables for the K-Series, LH-Series, and DLH-Series joists have shaded portions indicating which joist designations and spans require one or more rows of erection stability bridging.

Need Help?

If you start or are in the middle of a steel joist project and have questions, please contact the experts at SJI, which governs the design and manufacture of K-Series, LH-Series and DLH-Series joists and joist girders. If you would like to know more about open web steel joists and joist girders, help with an existing joist installation, or obtain

Standard vs. Special

Based on discussions with several structural engineers and joist manufacturers, there seems to be much confusion over when to specify a standard joist and when to use a special joist. Standard joists should be used for a member having a typical uniform load applied on the top chord for its entire length, and the selection of these joists can be found in SJI's *Standard Load Tables*. The advantages of using a standard joist include predetermined details, configurations, seat depths, bridging, and fire assemblies.

Special joists should be used for loading conditions other than a typical uniform load, such as drift loads, mechanical equipment loads (roof or interior hanging units or piping), partitions, special uplift, and seismic requirements.

If a special joist is being used, the structural engineer must determine if the load requirements for the joist can be adequately described in one gravity load case and one uplift load case. If yes, then the loads can all be pre-summed and specified as total (or factored) loads. If no, then the loads should be broken out by load category, and load combinations must be specified. These loads can be noted in several ways:

- individual load diagram
- additional notes on the framing plan
- load schedule
- separate loading plan

The end goal is for the joist design loads to be specified clearly and concisely. The difficulty is in knowing how to accomplish this, and the biggest stumbling block is in trying to pre-sum loads for conditions that require consideration of multiple load cases with different load category summations. Trying to mix a simple specification with a complex load condition almost always leads to confusion, loss of economy, and the potential for an inadequately designed joist for the situation.

—Joseph J. Pote
Director of Engineering – Research & Development, CMC Joist

contact information for a local or regional joist manufacturer, please visit www.steel-joist.org or call 843.626.1995. **MSC**

Perry Green is technical director of the Steel Joist Institute. Todd Alwood is a regional engineer with AISC.